



MODEL 15 m³/h (9 cfm)



OVERVIEW :

Our model 15 m³/h (9 cfm) is a scroll vacuum pump which is, like our other models, perfectly clean. Because of the simplicity of the design, low rotational speed, elimination of rubbing contact in the pump mechanism, and construction with corrosion-resistant materials, this pump is very reliable (30,000 hours of maintenance-free operation is typical in even the most severe applications). It is usually connected to a metal or elastomer diaphragm backing pump and then form a monobloc set which is easily transportable.

OPERATING PRINCIPAL :

The pumping device is made up of 2 overlaped scrolls ; one of them is moving and the other one is fixed. The movement is provided by 3 cranks-hafts (one is driving) with the same eccentricity. This movement causes the formation of chambers between the two spiral vanes. Once these chambers are formed, they remain closed, and as a result of the movement of one vane are progressively, continuously reduced in size and displaced towards a central exhaust port.

APPLICATIONS :

Our vacuum pumps are used all over the world to extract or circulate all kind of gases which can be aggressive, inert, toxic or radioactive (the only materials exposed to the vacuum environment are 316L and 420 stainless steel). Our model 15 m³/h is an ideal, dry, totally contamination-free roughing pump for applications such as evaporation, sputtering, scanning electron microscopes, tube evacuation and backfill stations. The pump has an ultimate vacuum capability of 5.10^{-3} mbar (with diaphragm backing pump) and, therefore, can serve as a roughing pump for systems using cryo, ion or turbomolecular pumps.

BENEFITS :

- Completely clean, dry and fluid tight vacuum pump
- Safety, reliability
- Low running and maintenance cost (no liquid nitrogen, no oil, long working life)
- Low noise and vibration level
- Air cooling (built-in fan)

ACCESSORIES :

- Fine inlet and outlet metal filter
- Transport trolley

TECHNICAL DATA :

Displacement :	
¥ 50 Hz operation	15 m ³ /h (8.8 ft ³ .min ⁻¹)
¥ 60 Hz operation	18 m ³ /h (10.6 ft ³ .min ⁻¹)
Peak pumping speed (50 Hz operation) :	12 m ³ /h (7.1 ft ³ .min ⁻¹)
Ultimate vacuum (with backing pump) :	5.10 ⁻³ mbar
Connections :	Meeting your need
Motor power	0.37 kW
Enclosure rating	IP 55
Motor voltage :	
¥ 3-phase 50 Hz	230-400 V
¥ 3-phase 60 Hz	240-480 V
Other voltage	On application
Weight	67 kg (148 lb)
Noise	51,5 dB(A)
Leak tightness (helium)	< 10 ⁻⁸ mbar.l.s ⁻¹

PERFORMANCES :

For the tests, the pump was connected to an elastomer diaphragm backing pump (Pumping rated speed : 22 NI/min - 0.78 ft³.min⁻¹ - and ultimate vacuum : 2 mbar abs)

Pumping speed characteristic for the model 15 m3/h with diaphragm pump (air)

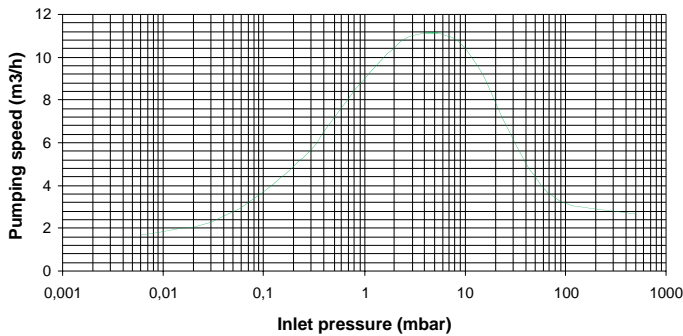

Pressure decrease in a 500 litres air vessel

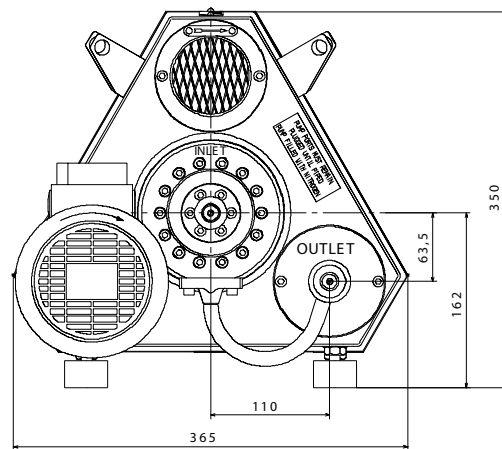
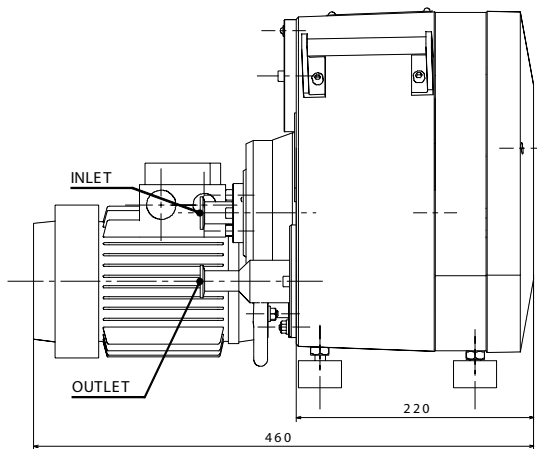
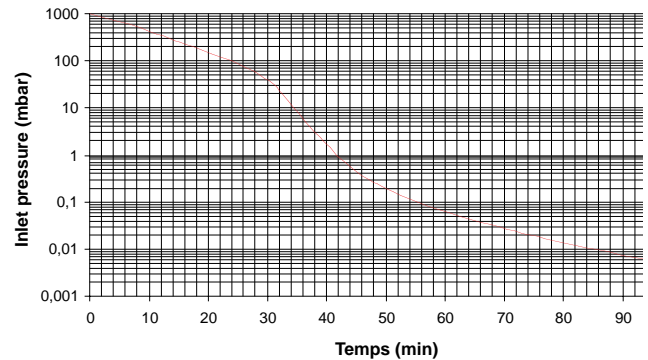

Your Authorized Distributor is: Stultz USA
 1-706-925-1220
www.StultzUSA.com
 Email: rfq@stultzusa.com